

Individual and Group Seating Armless Chair

The Sentinel Armless Chair is designed to stand alone or be bolted together. The ergonomic design provides maximum comfort using rotational molding technology.

FURNISHINGS & PRODUCTS
NOW INFUSED WITH

CORx

ANTIMICROBIAL COMPOUND

FEATURES:

- Durable, one piece, rotationally molded design for increased strength. Constructed of high impact “no break” polyethylene. No steel or wood components
- Can be bolted together or in place via concealed pilot holes
- Can be easily filled with sand through optional ballast door and secures with tamper resistant screws
- Sound dampening
- Easy to clean, sanitize & maintain
- Passes Flammability UL 94 HB
- Tested to ISO 22196 showing a >99% reduction in bacteria
- Flame Retardant (passes Cal 133)
Test reports available upon request
- Manufactured to ISO Quality Standards in the USA 

**10 Year
Factory Warranty**

33H x 24W x 24D

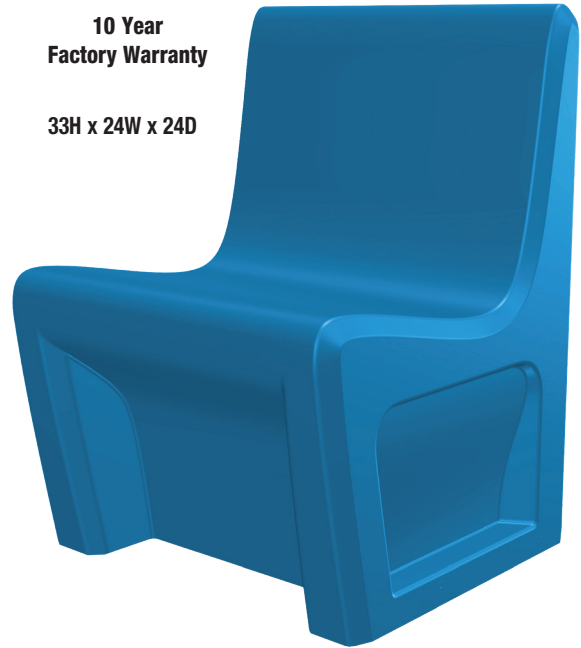

ITEM	COLOR
116484AQ	Aqua
116484BK	Black
116484BG	Blue Gray
116484BN	Brown
116484BY	Burgundy
116484GY	Gray
116484GN	Green
116484IG	Indigo
116484MB	Midnight Blue
116484SD	Sand
116484SB	Slate Blue
116484SG	Stone Gray

ITEM	COLOR
116484AQS	Aqua with Access Door
116484BKS	Black with Access Door
116484BGS	Blue Gray with Access Door
116484BNS	Brown with Access Door
116484BYS	Burgundy with Access Door
116484GYS	Gray with Access Door
116484GNS	Green with Access Door
116484IGS	Indigo with Access Door
116484MBS	Midnight Blue with Access Door
116484SDS	Sand with Access Door
116484SBS	Slate Blue with Access Door
116484SGS	Stone Gray with Access Door

Available in



Custom colors available upon request. Call Cortech for details.

OVERVIEW

The Sentinel Armless Chair is designed to stand alone or be bolted together. The ergonomic design provides maximum comfort using rotational molding technology. **Manufactured to ISO Quality Standards in the USA.**

FABRICATION/MATERIAL

Durable, one piece, rotationally molded design for increased strength. Constructed with high impact “no break” polyethylene. No steel or wood components Flame Retardant (as shown passes Cal 133). Test reports available upon request.

COLOR Black, Blue Gray, Brown, Burgundy, Gray, Green, Sand and Slate Blue. Custom colors available upon request.

WEIGHT 30 lbs.

OPTIONS Can be bolted to the floor via concealed pilot holes and can be filled with sand through ballast door on site to weigh down. Hardware bit size: T27.

WARRANTY 10 Year Factory Warranty.

MAINTENANCE Easy to clean, sanitize & maintain.

FRONT

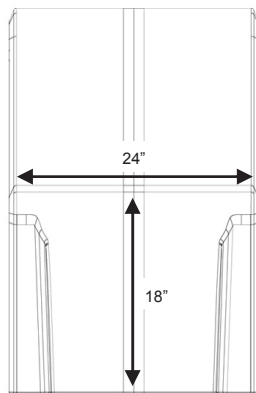

SIDE

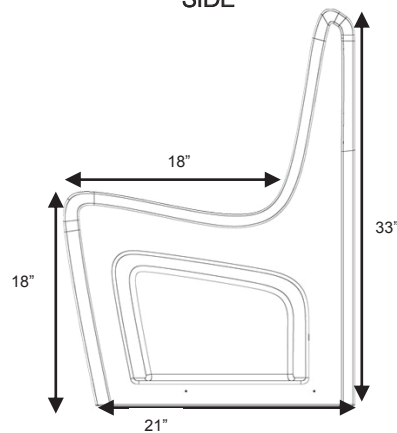

TOP

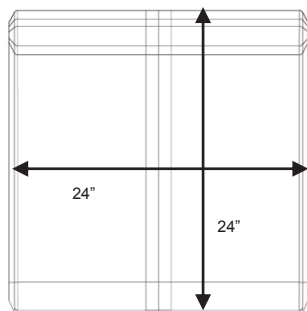

BACK w/ACCESS DOOR

